

SONY®



COLOUR BLOCK CAMERAS

FCB-PV Series

FCB-PV480

FCB-PV10

www.sonybiz.net/vision



New high quality Sony FCB-PV progressive scan colour block cameras expand application solutions by combining renowned Sony FCB picture quality and a digital video interface.

The popular Sony FCB colour block camera series are used in a variety of applications ranging from surveillance to traffic monitoring and in many other visual communication environments. These cameras are specifically designed to easily integrate into security domes, police vehicles, photo booths, document stands, video-conferencing and low vision systems.

Sony is expanding its FCB camera series to include, for the first time, Progressive Scan (PS) colour block models. The FCB-PV Series features Progressive Scan CCD technology with square pixels, Primary Colour filters for precise colour reproduction and a digital YUV 4:2:2 interface. The new FCB-PV480 colour block camera incorporates a 1/4-type Super HAD™ PS CCD with an 18x optical zoom lens. The ultra-compact FCB-PV10 colour block camera incorporates a 1/4-type Super HAD PS CCD with a 10x optical zoom lens. In addition, the FCB-PV480 camera can operate with a minimum illumination of 1.6 lux and is equipped with Auto ICR (IR cut filter removal) for near-infrared sensitivity. Both cameras output a VGA size image (640 x 480) and offer frame rates of 29.97 or 25 fps (switchable).

These FCB-PV cameras are the perfect match for IP camera applications that require a direct digital video connection. With their digital video interface, the FCB-PV Series enables OEMs to easily integrate these cameras with fewer conversions such as A/D and I/P (interlace to progressive) in their systems, resulting in outstanding image quality and lower system cost.

The new Sony FCB-PV Series combines unique features with many convenient functions inherited from previous FCB models. These FCB-PV cameras are an optimum solution for high-speed shooting applications, such as traffic monitoring, license plate capture, and monitoring from mobile police vehicles, thanks to its progressive scan CCD sensor that produces high-quality images with crisp edges. They are also a powerful solution when it comes to still image applications. With their Primary Colour filters and square pixel CCD, the FCB-PV cameras achieve precise colour reproduction and exceptional picture quality - a must for videoconferencing, low vision, photo booths, and document stands.



MAIN FEATURES

- Progressive Scan Colour Block Camera with Auto Focus Zoom Lens
 - 1/4-type Super HAD CCD – Approximately 330,000 pixels
 - Excellent Colour Reproduction with Primary Colour Filters
- 18x Optical Zoom Capability – FCB-PV480
10x Optical Zoom Capability – FCB-PV10
- Digital Interface with Selectable Modes
 - Clear Capture of Moving Objects – Sharp, Clean Edges
 - Auto IR-Cut Filter Removal (ICR) - FCB-PV480 only
 - Advanced Spherical Privacy Zone Masking Function with Mosaic Effect
 - Electronic-Flip (E-Flip) Function
 - Alarm Functions
 - Picture Freeze Function
 - Spot AE Function
 - Electronic Shutter/Slow Shutter (long time exposure)
 - High-Speed Serial Interface (max. 38.4 Kb/s) and TTL Signal-Level Control (VISCATM protocol)
 - Various Customisable Settings
 - Internal Sync.
 - Low Power Consumption (1.6 W when motors are inactive)
 - 16-Bytes of Available Memory for Recording Data such as Product Serial Number
- Lead-free Solder and Halogen-free Printed Circuit Boards

FEATURE DESCRIPTIONS

HIGH-QUALITY IMAGES

- **1/4-type Super HAD CCD with Primary Colour Filters and Square Pixels**

Adopting a 1/4-type Super HAD CCD with Primary Colour filters and Square Pixels, the FCB-PV block cameras deliver exceptional picture quality, excellent colour reproduction and eliminate the need for pixel-size conversion.

- **Clear Progressive Scan Images**

The FCB-PV camera series incorporate progressive scan technology that can help eliminate blurred, illegible characters and jagged edges. For example, this technology is useful in traffic surveillance applications that require the capture of a car license plate image, or with low vision systems that require written or typed documents to be moved.

Conventional Cameras



SONY FCB-PV Cameras



VERSATILE DIGITAL INTERFACES WITH SELECTABLE MODES

- The FCB-PV Series comes equipped with a digital interface. For output flexibility, these cameras offer YUV 4:2:2 signals in six selectable modes as shown in the table opposite.

I/F Mode	Output	SYNC	Frame Rate	Clock
16-bit Progressive Word Parallel, Bit Parallel	YUV 16-bit 4:2:2	HSYNC/VSYNC	29.97 frames/sec 25.0 frames/sec	13.5 MHz
8-bit Progressive Word Serial, Bit Parallel	YUV 8-bit 4:2:2	HSYNC/VSYNC SAV/EAV	29.97 frames/sec 25.0 frames/sec	27.0 MHz
8-bit Progressive Word Serial, Bit Parallel	YUV 8-bit 4:2:2	HSYNC/VSYNC SAV/EAV	59.94 frames/sec 50.0 frames/sec	27.0 MHz

- **16-bit Output Signals**

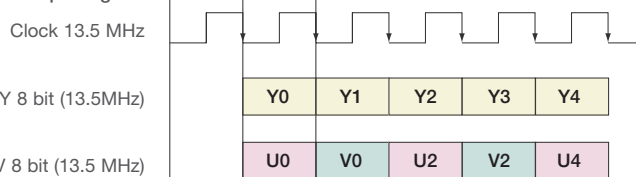

- **8-bit Output Signals**

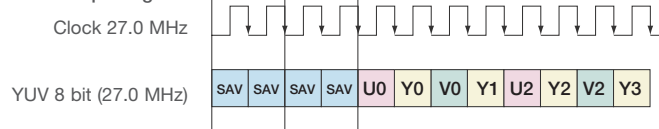

ALARM FUNCTIONS

- The FCB-PV Series provides an Alarm function that detects changes in the AF, AE, or both AF and AE levels of an image and outputs an alarm signal as required to external equipment via its control interface using the VISCA protocol. This feature is ideal for automatically performing functions such as sounding an audible alarm or triggering an electric strike to lock or unlock a door when focus or luminance levels change.

These cameras are also equipped with a Spot AE function that allows them to detect changes in AE levels of designated areas of the images, and output an alarm signal accordingly. Users can designate multiple detecting areas from any of 16 vertical and 16 horizontal blocks. In addition, these cameras feature a DAY/NIGHT mode that can output an alarm signal via the VISCA protocol in response to a change in the designated brightness/darkness level.

- **Enhanced Spherical Privacy Zone Masking with Mosaic Effect**
With the FCB-PV Series, unwanted or prohibited areas within an image can be masked with a mosaic effect in addition to conventional colour masking with colours such as black, gray, white, red, green, blue, cyan, yellow and magenta. The prohibited areas are interlocked with Pan/Tilt/Zoom movements for comprehensive masking. A maximum of 24 masking areas can be preset to any of 160 horizontal and 120 vertical masking blocks. In addition, up to eight masking presets can be set for a specific image. A maximum of two different colours (including the mosaic pattern) can be displayed in a single image.

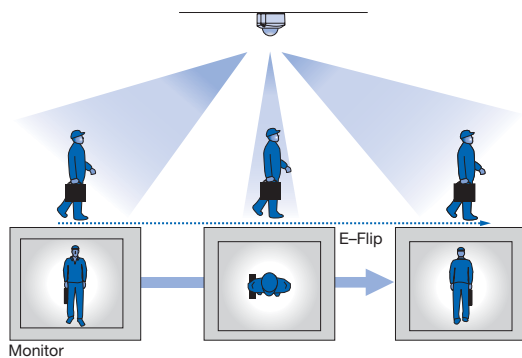
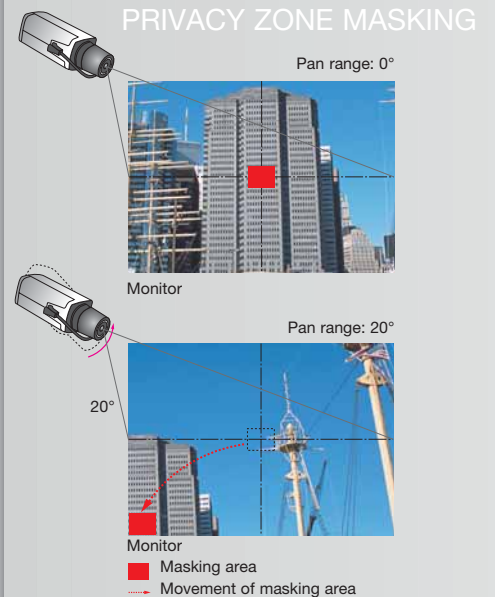

- For optimised sensitivity in both day and night-time shooting applications, the FCB-PV480 camera incorporates an Auto ICR function. With a set level of darkness, the IR Cut filter is automatically disabled (ICR ON) and the infrared sensitivity is increased. With a set level of brightness, the filter is automatically enabled (ICR OFF). The ICR automatically engages depending on the ambient light, allowing the camera to be effective in a variety of lighting conditions.

- The FCB-PV Series is equipped with a Picture Freeze function that allows for the output of a still image while the camera is panning, tilting, zooming, focusing, initialising the lens, or performing preset operations. For example, the camera will output a still image before it begins to pan, tilt, or zoom, and once the operation is completed, the camera continues to display images; unnecessary images are not displayed.

¹ A change to the default setting is required to activate this function.

- The AE area of the FCB-PV Series is selected from one of the 16 vertical/16 horizontal blocks of the image to optimise brightness within the desired area.

- The FCB-PV Series uses lead-free solder and halogen-free printed circuit boards.

ELECTRONIC-FLIP (E-FLIP)

- The FCB-PV cameras have an E-Flip function that electronically flips an image upside down so that it is displayed on the monitor accurately. In a dome application for example, if a tracked object moves beneath the camera dome, the image can be inverted to maintain the correct orientation.

AUTO IR CUT FILTER REMOVAL (ICR) (FCB-PV480 only)

PICTURE FREEZE¹

SPOT AE

ENVIRONMENTALLY FRIENDLY LEAD-FREE DESIGN

PIN ASSIGNMENT & CONNECTOR

FCB-PV480

CN501 24P FFC for Digital Image Data

Pin No.	Name	16 bit data bus	Level	8 bit data bus	Level
1	GND	Signal Ground	--	--	--
2	Y0	Digital Y-Out 0	0 - 3.3 Vp-p	Digital Out 0	0 - 3.3 Vp-p
3	Y1	Digital Y-Out 1	0 - 3.3 Vp-p	Digital Out 1	0 - 3.3 Vp-p
4	Y2	Digital Y-Out 2	0 - 3.3 Vp-p	Digital Out 2	0 - 3.3 Vp-p
5	Y3	Digital Y-Out 3	0 - 3.3 Vp-p	Digital Out 3	0 - 3.3 Vp-p
6	Y4	Digital Y-Out 4	0 - 3.3 Vp-p	Digital Out 4	0 - 3.3 Vp-p
7	Y5	Digital Y-Out 5	0 - 3.3 Vp-p	Digital Out 5	0 - 3.3 Vp-p
8	Y6	Digital Y-Out 6	0 - 3.3 Vp-p	Digital Out 6	0 - 3.3 Vp-p
9	Y7	Digital Y-Out 7	0 - 3.3 Vp-p	Digital Out 7	0 - 3.3 Vp-p
10	GND	Signal Ground	--	--	--
11	C0	Digital C-Out 0	0 - 3.3 Vp-p	Hi imp	--
12	C1	Digital C-Out 1	0 - 3.3 Vp-p	Hi imp	--
13	C2	Digital C-Out 2	0 - 3.3 Vp-p	Hi imp	--
14	C3	Digital C-Out 3	0 - 3.3 Vp-p	Hi imp	--
15	C4	Digital C-Out 4	0 - 3.3 Vp-p	Hi imp	--
16	C5	Digital C-Out 5	0 - 3.3 Vp-p	Hi imp	--
17	C6	Digital C-Out 6	0 - 3.3 Vp-p	Hi imp	--
18	C7	Digital C-Out 7	0 - 3.3 Vp-p	Hi imp	--
19	GND	Signal Ground	--	--	--
20	VSYNC	Vertical SYNC	0 - 3.3 Vp-p	--	0 - 3.3 Vp-p
21	HSYNC	Horizontal SYNC	0 - 3.3 Vp-p	--	0 - 3.3 Vp-p
22	GND	Signal Ground	--	--	--
23	CLOCK	Clock signal	0 - 3.3 Vp-p	--	0 - 3.3 Vp-p
24	GND	Signal Ground	--	--	--

Connector: KYOCERA ELCO 046240024006848+ (0.5 mm)

CN701 10P FFC for Power And Communication

Pin No.	Name	Level
1	UNREG	Power Input 6.0 - 12.0 V (dc)
2	UNREG	Power Input 6.0 - 12.0 V (dc)
3	UNREG	Power Input 6.0 - 12.0 V (dc)
4	UNREG	Power Input 6.0 - 12.0 V (dc)
5	GND	Ground --
6	GND	Ground --
7	GND	Ground --
8	GND	Ground --
9	TD	TTL level (0 - 5.0 Vp-p)
10	SD	TTL level (0 - 5.0 Vp-p)

Connector: KYOCERA ELCO 046240010006848+ (0.5 mm)

CN702 4P-4P Harness for Power And Communication

Pin No.	Name	Level
1	UNREG	Power Input 6.0 - 12.0 V (dc)
2	GND	Ground --
3	TD	TTL level (0 - 5.0 Vp-p)
4	RD	TTL level (0 - 5.0 Vp-p)

Connector: J.S.T. Mfg Co. S4B-ZR-SM4A-TF(LF)

CN403 12P FFC for Key Switch Control

Pin No.	Name	Level
1	GND	--
2	GND	--
3	KEY_AD0	Pull up to 3.0 V by 100 kΩ
4	KEY_AD1	Pull up to 3.0 V by 100 kΩ
5	KEY_AD2	Pull up to 3.0 V by 100 kΩ
6	KEY_AD3	Pull up to 3.0 V by 100 kΩ
7	KEY_AD4	Pull up to 3.0 V by 100 kΩ
8	KEY_AD5	Pull up to 3.0 V by 100 kΩ
9	KEY_AD6	Pull up to 3.0 V by 100 kΩ
10	KEY_AD7	Pull up to 3.0 V by 100 kΩ
11	NC	--
12	Strobe	Strobe timing pulse (0 to 3.0 V)

Connector: KYOCERA ELCO 086222012101848+ (0.5 mm)

FCB-PV10

CN501 24P FFC for Digital Image Data

Pin No.	Name	16 bit data bus	Level	8 bit data bus	Level
1	GND S	Digital Ground	--	--	--
2	Y0	Digital Y-Out 0	0 - 3.3 Vp-p	Digital Out 0	0 - 3.3 Vp-p
3	Y1	Digital Y-Out 1	0 - 3.3 Vp-p	Digital Out 1	0 - 3.3 Vp-p
4	Y2	Digital Y-Out 2	0 - 3.3 Vp-p	Digital Out 2	0 - 3.3 Vp-p
5	Y3	Digital Y-Out 3	0 - 3.3 Vp-p	Digital Out 3	0 - 3.3 Vp-p
6	Y4	Digital Y-Out 4	0 - 3.3 Vp-p	Digital Out 4	0 - 3.3 Vp-p
7	Y5	Digital Y-Out 5	0 - 3.3 Vp-p	Digital Out 5	0 - 3.3 Vp-p
8	Y6	Digital Y-Out 6	0 - 3.3 Vp-p	Digital Out 6	0 - 3.3 Vp-p
9	Y7	Digital Y-Out 7	0 - 3.3 Vp-p	Digital Out 7	0 - 3.3 Vp-p
10	GND	Signal Ground	--	--	--
11	C0	Digital C-Out 0	0 - 3.3 Vp-p	Hi imp	--
12	C1	Digital C-Out 1	0 - 3.3 Vp-p	Hi imp	--
13	C2	Digital C-Out 2	0 - 3.3 Vp-p	Hi imp	--
14	C3	Digital C-Out 3	0 - 3.3 Vp-p	Hi imp	--
15	C4	Digital C-Out 4	0 - 3.3 Vp-p	Hi imp	--
16	C5	Digital C-Out 5	0 - 3.3 Vp-p	Hi imp	--
17	C6	Digital C-Out 6	0 - 3.3 Vp-p	Hi imp	--
18	C7	Digital C-Out 7	0 - 3.3 Vp-p	Hi imp	--
19	GND	Signal Ground	--	--	--
20	VSYNC	Vertical SYNC	0 - 3.3 Vp-p	--	0 - 3.3 Vp-p
21	HSYNC	Horizontal SYNC	0 - 3.3 Vp-p	--	0 - 3.3 Vp-p
22	GND	Signal Ground	--	--	--
23	CLOCK	Clock signal	0 - 3.3 Vp-p	--	0 - 3.3 Vp-p
24	GND	Signal Ground	--	--	--

Connector: KYOCERA ELCO 046240024006848+ (0.5 mm)

CN701 4P-4P Harness for Power And Communication

Pin No.	Name	Level
1	UNREG	Power Input 6.0 - 12.0 V (dc)
2	GND	Ground --
3	TD	TTL level (0 - 5.0 Vp-p)
4	RD	TTL level (0 - 5.0 Vp-p)

Connector: J.S.T. Mfg Co. S4B-ZR-SM4A-TF(LF)

FCB-PV480



FCB-PV10



SPECIFICATIONS

FCB-PV480

Image sensor	1/4-type Super HAD CCD
Number of total pixels	Approx. 330,000 pixels (659(H) x 494(V))
Image size	VGA (640 x 480)
Lens	18x zoom, f=4.1 mm (wide) to 73.8 mm (tele), F1.4 to F3.0
Viewing Angle (H)	48° (wide end) to 2.8° (tele end)
Minimum working distance	290 mm (wide end), 800 mm (tele end)
Sync system	Internal
Minimum illumination	1.6 lx (F1.4, 50 IRE)
S/N ratio	More than 50 dB
Electronic shutter	1/1 to 1/10,000 s (22 steps)
White balance	Auto, ATW, Indoor, Outdoor, One-push, Manual
Gain	Auto / Manual (-3 to 28 dB, 2 dB steps)
AE control	Auto, Manual, Priority mode (shutter priority & iris priority), Bright
Backlight compensation	On/Off
Privacy zone masking	On/Off (24 positions)
Focusing system	Auto (Sensitivity: normal, low), One-push AF, Manual, Infinity, Interval AF, Zoom Trigger AF
Picture effects	E-Flip, Black & White, Mirror Image
Video output	YUV 4:2:2 (16-bit/13.5 MHz or 8-bit/ 27.0 MHz)
Camera control interface	VISCA (TTL signal level), baud rate: 9.6 Kb/s, 19.2 Kb/s, 38.4 Kb/s, 1 or 2 stop bit selectable
Storage temperature	-20°C to 60°C (-4 to 140°F)
Operating temperature	0°C to 50°C (32 to 122°F)
Power consumption	6.0 V to 12.0 V DC 1.5 W (motors inactive), 2.7 W (motors active)
Dimensions (W x H x D)	52.0 x 57.5 x 92.6 mm (2 1/8 x 2 3/8 x 3 3/8 inches)
Lens adaptor screw	Yes
Mass	230 g (8.1 oz)
Supplied accessories	24P FFC, 10P FFC, 4P-4P harness, Ferrite ring

FCB-PV10

Image sensor	1/4-type Super HAD CCD
Number of total pixels	Approx. 330,000 pixels (659(H) x 494(V))
Image size	VGA (640 x 480)
Lens	10x zoom, f=4.2 mm (wide) to 42.0 mm (tele), F1.8 to F2.9
Viewing Angle (H)	46° (wide end) to 4.6° (tele end)
Minimum working distance	10 mm (wide end), 1,000 mm (tele end)
Sync system	Internal
Minimum illumination	2.3 lx (F1.8, 50 IRE)
S/N ratio	More than 50 dB
Electronic shutter	1/1 to 1/10,000 s (22 steps)
White balance	Auto, ATW, Indoor, Outdoor, One-push, Manual
Gain	Auto / Manual (-3 to 28 dB, 2 dB steps)
AE control	Auto, Manual, Priority mode (shutter priority & iris priority), Bright
Backlight compensation	On/Off
Privacy zone masking	On/Off (24 positions)
Focusing system	Auto (Sensitivity: normal, low), One-push AF, Manual, Infinity, Interval AF, Zoom Trigger AF
Picture effects	E-Flip, Black & White, Mirror Image
Video output	YUV 4:2:2 (16-bit/13.5 MHz or 8-bit/ 27.0 MHz)
Camera control interface	VISCA (TTL signal level), baud rate: 9.6 Kb/s, 19.2 Kb/s, 38.4 Kb/s, 1 or 2 stop bit selectable
Storage temperature	-20°C to 60°C (-4 to 140°F)
Operating temperature	0°C to 50°C (32 to 122°F)
Power consumption	6.0 V to 12.0 V DC 1.5 W (motors inactive), 2.7 W (motors active)
Dimensions (W x H x D)	37.3 x 43.8 x 61.0 mm (1 1/2 x 1 3/8 x 2 1/2 inches)
Lens adaptor screw	Yes
Mass	84 g (2.9 oz)
Supplied accessories	24P FFC, 4P-4P harness, Ferrite ring

DIMENSIONS

FCB-PV480

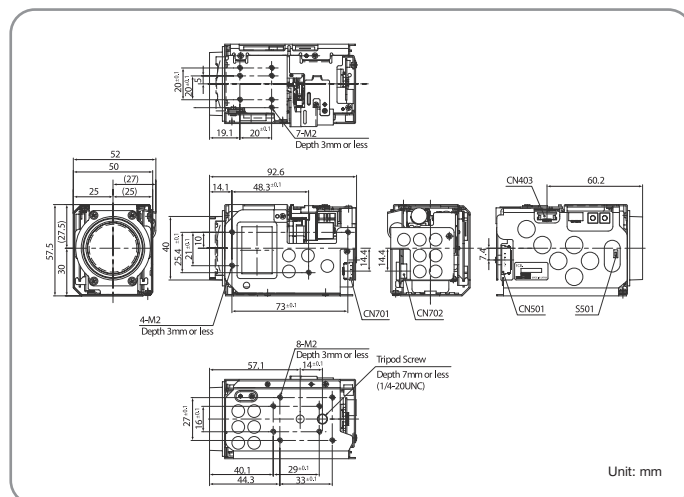

Right side view



Rear view



Left side view

FCB-PV10

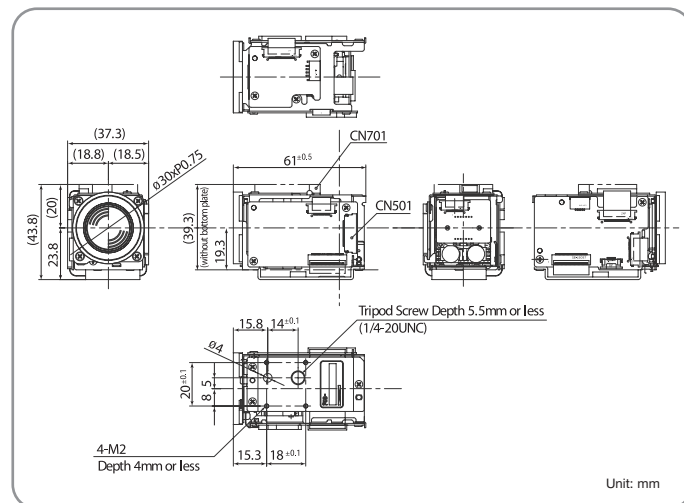

Right side view



Rear view



Left side view