

OWL SW1.7CL 320

Rugged, high sensitivity, digital SWIR camera

Preliminary

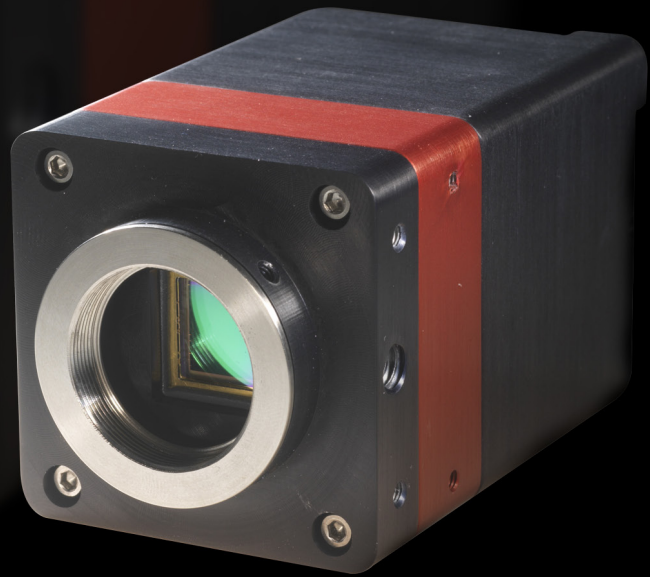

Key Features and Benefits

SWIR technology with Optional Visible Extension

- **14 bit CameraLink output.**
Enables high speed digital video with intelligent auto AGC
- **On-board Automated Gain Control (AGC).**
Enables clear video in all light conditions
- **On-board intelligent 3 point NUC.**
Enables highest quality images
- **Ultra compact, Low power (< 5W).**
Ideal for hand-held, mobile or airborne systems
- **Rugged, No fan.**
Enables integration into UAV, handheld or any Electro-Optic system

Resolution	320 x 256
Frame Rate	25/30/50/60 Hz
CameraLink	14 bit
Wavelength Range	VIS-SWIR



..... Capturing Tomorrow

Specification for OWL SW1.7 CL-320

FPA Specification	
Sensor	Alcatel-Thales III-V Lab
Sensor Type	InGaAs PIN-Photodiode
Active Pixel	320 x 256
Pixel Pitch	30µm x 30µm
Active Area	9.6mm x 7.68mm
Spectral response ¹	0.9µm to 1.7µm or 0.4µm to 1.7µm
Noise (RMS)	<150 electrons
Quantum Efficiency	>70% @ 1.5µm
Pixel Operability	>99%
Camera Specification	
Digital Output Format	14 bit CameraLink (Base Configuration)
Exposure time	500ns to 1 / frame rate
Shutter mode	Global shutter
Frame Rate	25Hz, 30Hz, 50Hz or 60Hz
Optical Interface	C mount (selection of SWIR lens available)
Camera Setup / Control	CameraLink
Dynamic Range	14 bit
Trigger interface	Trigger IN and OUT - TTL compatible
Power supply	12V DC ±10%
TE Cooling	ON / OFF
Image Correction	3 point NUC (offset, Gain & Dark Current) + pixel correction
Functions controlled by serial communication	Exposure, intelligent AGC, Non Uniformity Correction, Gamma, Pk/Av, TEC, ROI
Camera Power Consumption ²	< 5W without TEC
Operating Case Temperature ³	-20°C to +55°C
Storage Temperature	-30°C to +60°C
Dimensions & Weight	50mm x 50mm x 82mm / 282g

Quantum Efficiency

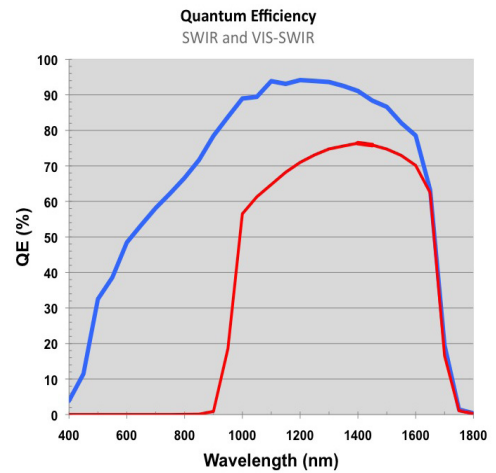

Sample Applications

- 860, 1064 & 1550nm laser line detection
- Active Imaging
- Airborne Payload
- Hand Held Goggles
- Imaging through fog
- Range finding
- Vision enhancement
- Semiconductor Inspection
- Solar Cell Inspection
- Telecommunications
- Thermography
- Astronomy
- Telecommunications

Raptor Photonics Limited reserves the right to change this document at any time without notice and disclaims liability for editorial, pictorial or typographical errors.

Note 1: Optional filters available: Low, High or bandpass

Note 2: Additional up to 5W with TEC switched on

Note 3: Extended Operating Temperature range on request

Dimensions

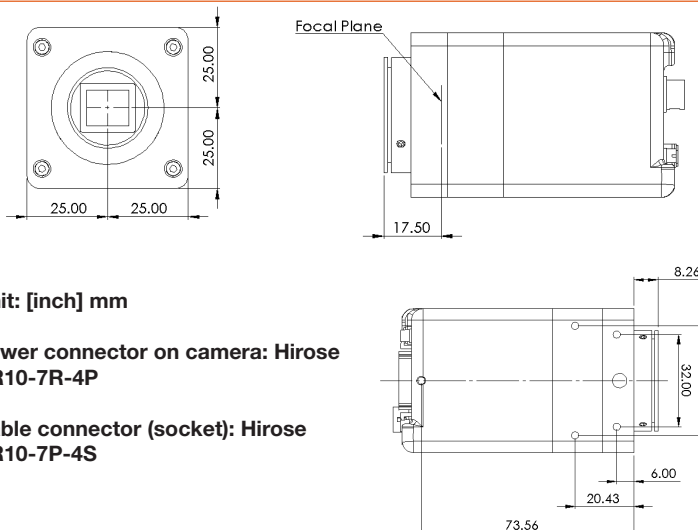

Unit: [inch] mm

Power connector on camera: Hirose HR10-7R-4P

Cable connector (socket): Hirose HR10-7P-4S

Document #: OWL1.7-CL-320 0912PR1

Ordering Information

Camera

OWL SWIR digital camera OW1.7-CL-320

OWL Power Supply Cable RPL-HR4-K

Optional Accessories

Epix base CL card RPL-EPIX-EB1

Epix base notebook CL card RPL-EPIX-ECB1-54

Epix Xcap ltd software RPL-XCAP-LTD

CameraLink Cable, 2m⁴ RPL-CL-CBL-2M

Optical SWIR lenses⁵ RPL-xx-xxxx

Note 4: Longer CL cable available

Note 5: Please consult us to check our range of lenses

Equipment may require UK Government authorisation for export purposes